

Free - Flight

By Roy L. Clough, Jr.

PARASOL PLANE

It may look like a flying dinner plate, but this way-out model is actually a rugged performer that will draw a big hand at any flying site

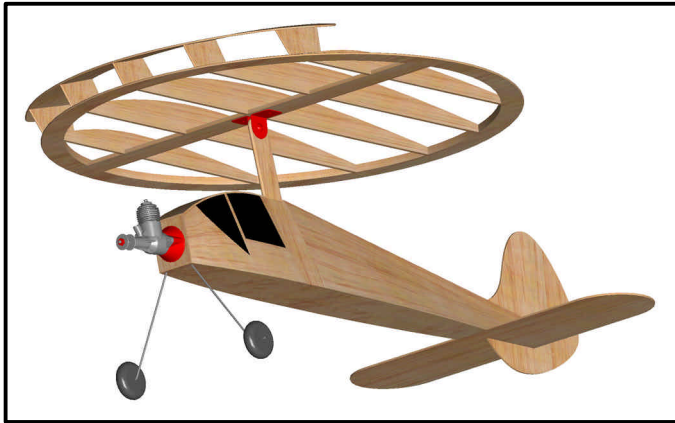

ONE OF THE MOST unusual designs in the history of aircraft is the pancake wing, a weird-looking bird which actually has a number of features to recommend it,

A circular wing presents little drag at low angles of attack, making it fine for high-speed cruising. At high angles of attack the wing develops a great amount of lift and drag, perfect characteristics for low-speed landings. The sharply curved leading edge is an effective substitute for stabilizing dihedral angle.

As an extra feature on this model, "eyebrow" slots have been added to permit climbing at steep angles without stalling.

Construction begins with the fuselage. Cut out the two sides and cement them together along the top edges, starting at the tail end and working as far forward as the strut. Insert the bulkheads and the wing strut, and then add the cabin roof cut from 1/16-in. balsa sheet mounted cross-grain. Note that the firewall must be shaped to fit the contour at the top,

When the cement is dry, install the elevator and cover the bottom of the fuselage with balsa sheet laid cross-grain. Slip the rudder into place and cap-strip the top fuselage joint with a strip of 1/16-in. balsa sanded to the proper contour.

Make up the wing outline from two layers of scrap 1/8-in. balsa sheet. The joints in the bottom layer may be located at random, provided they are lapped with solid balsa in the second layer. Sand this outline to shape before installing the spar and ribs. Next, make the wing brackets and attach them to the underside of the spar with cement and two 2-56 bolts.

Cover the wings with lightweight gas-model tissue, applying it in strips between the ribs in the upper surface, then spray this lightly with water to shrink it and pin the wing to a flat rigid surface to prevent warping during drying. When dry, coat the covered wing with a couple of thin coats of butyrate dope.

The top piece forming the eyebrow slot is cut from 1/16-in. sheet balsa and supported on flow separators cemented to the top of the wing. Note that the contour of the wing ribs changes from the center outward. When the eyebrow top is cemented to the separators, the result will be a down twist at the outer ends. This assists in producing the desired airflow condition over the center - a sound design practice, which prevents the model from tipping.

Attach the wing to the strut with brackets and a 6-32 bolt, then add the decorations and give the whole fuselage a coat of clear butyrate.

To discover the best wing angle, glide the model over long grass until you achieve a smooth, flat glide, then tighten the bolt. Finally, start the motor and test-fly the model to find the rudder adjustment which yields the proper angle of climb.

The rudder controls the angle of climb. If model climbs too steeply, tighten turn by bending the rudder tap (bend the staples with a small pair of pliers). It's recommended that you fly it in left-hand circles to take advantage of stabilizing gyroscopic moment provided by the right-hand propeller.

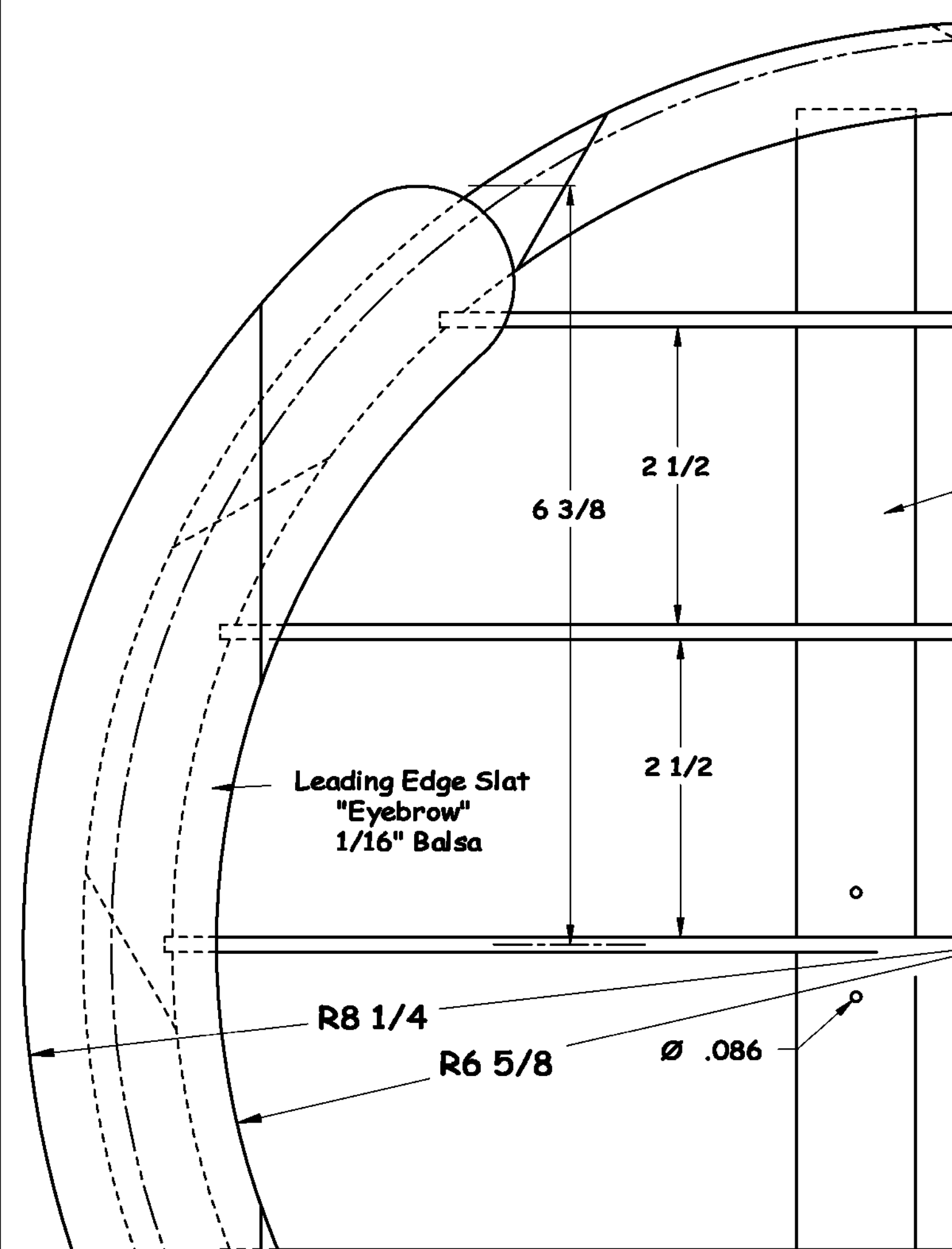

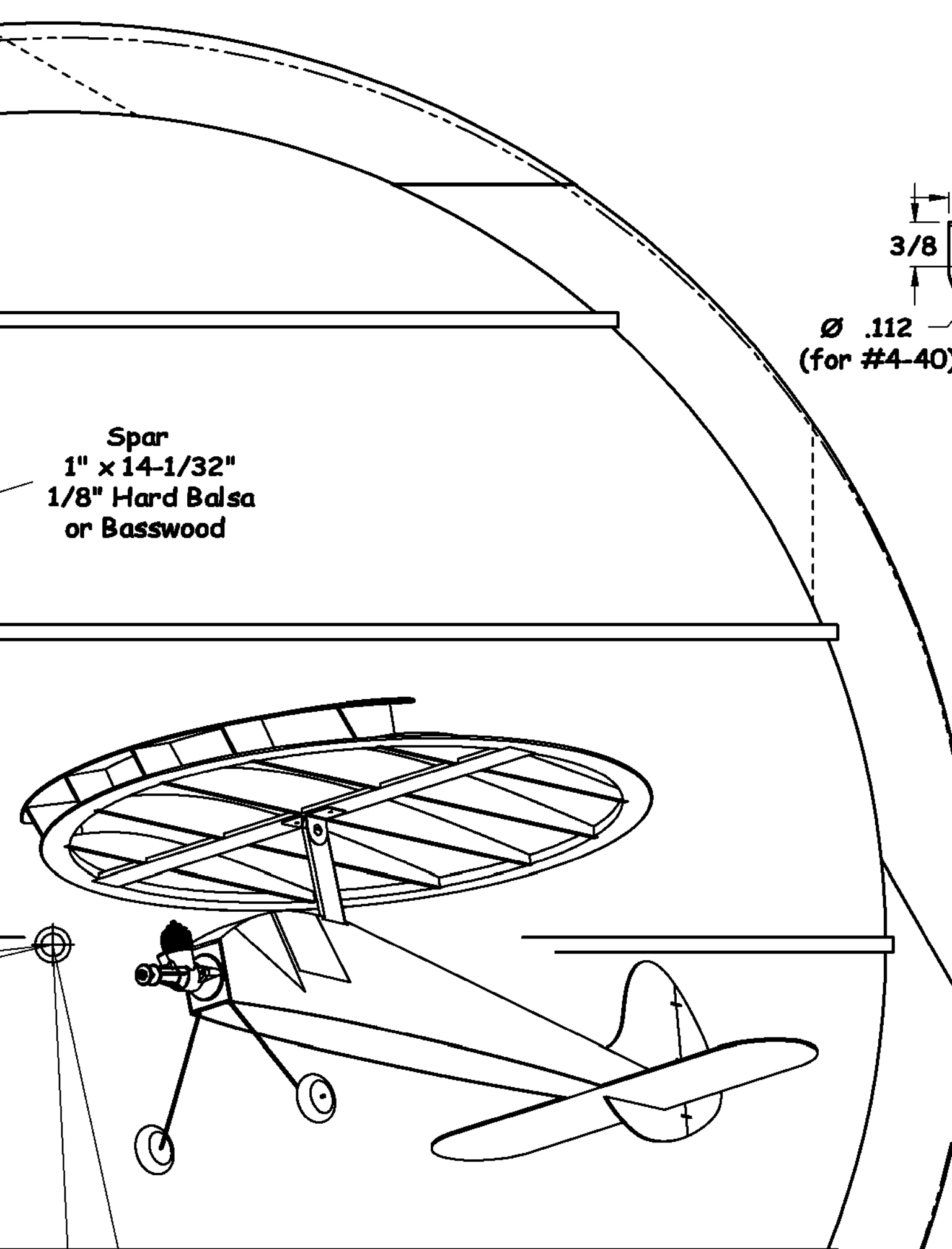

3/8

Ø .112
(for #4-40)

Spar
1" x 14-1/32"
1/8" Hard Balsa
or Basswood

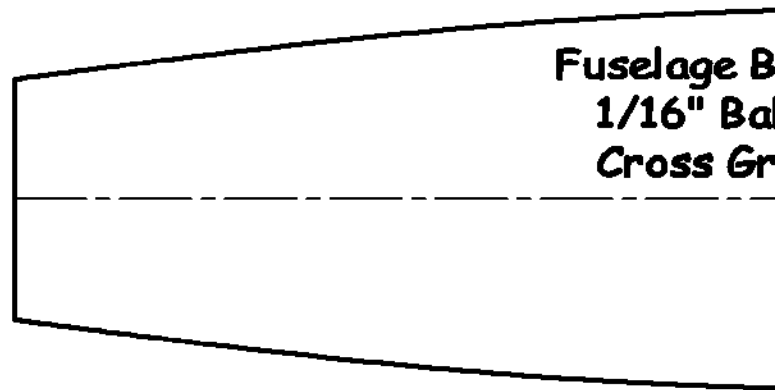
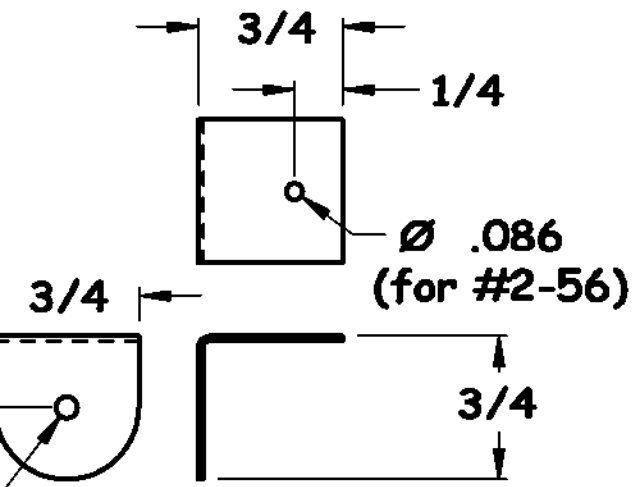

Wing Brackets
 .024" Aluminum

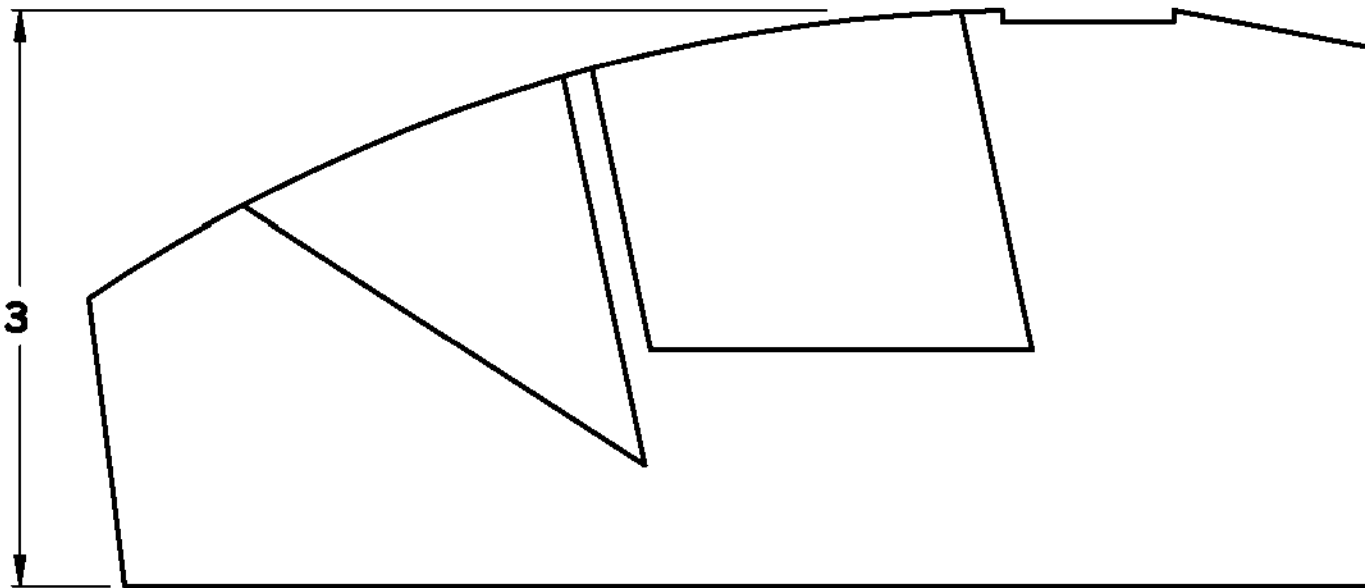
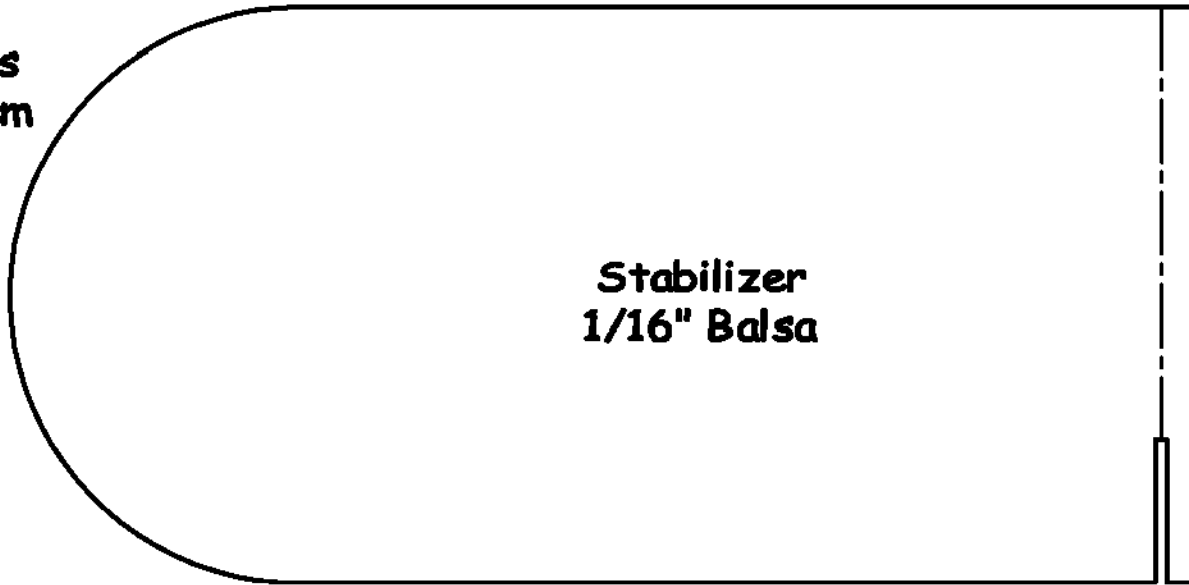

Bottom
Balsa
Main

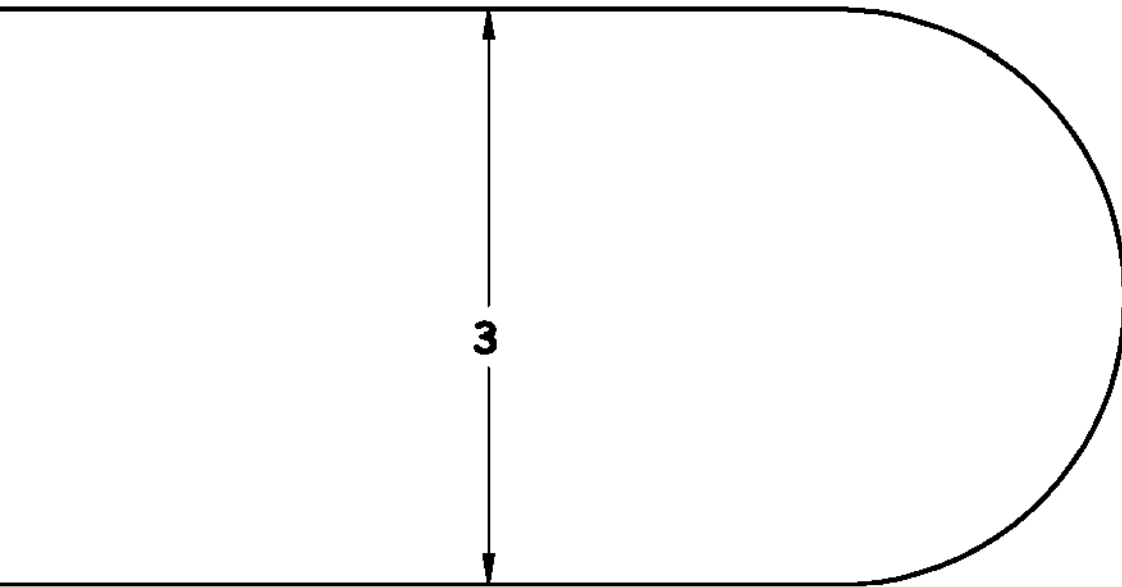

**Fuselage Sides
Flat Pattern
1/16" Balsa**

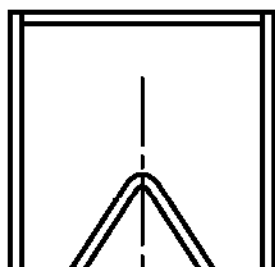
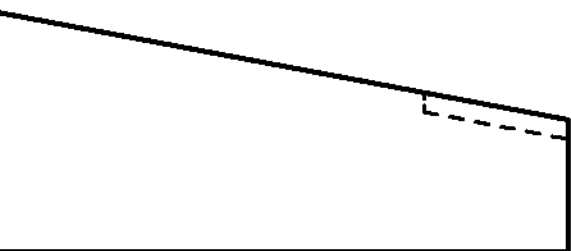
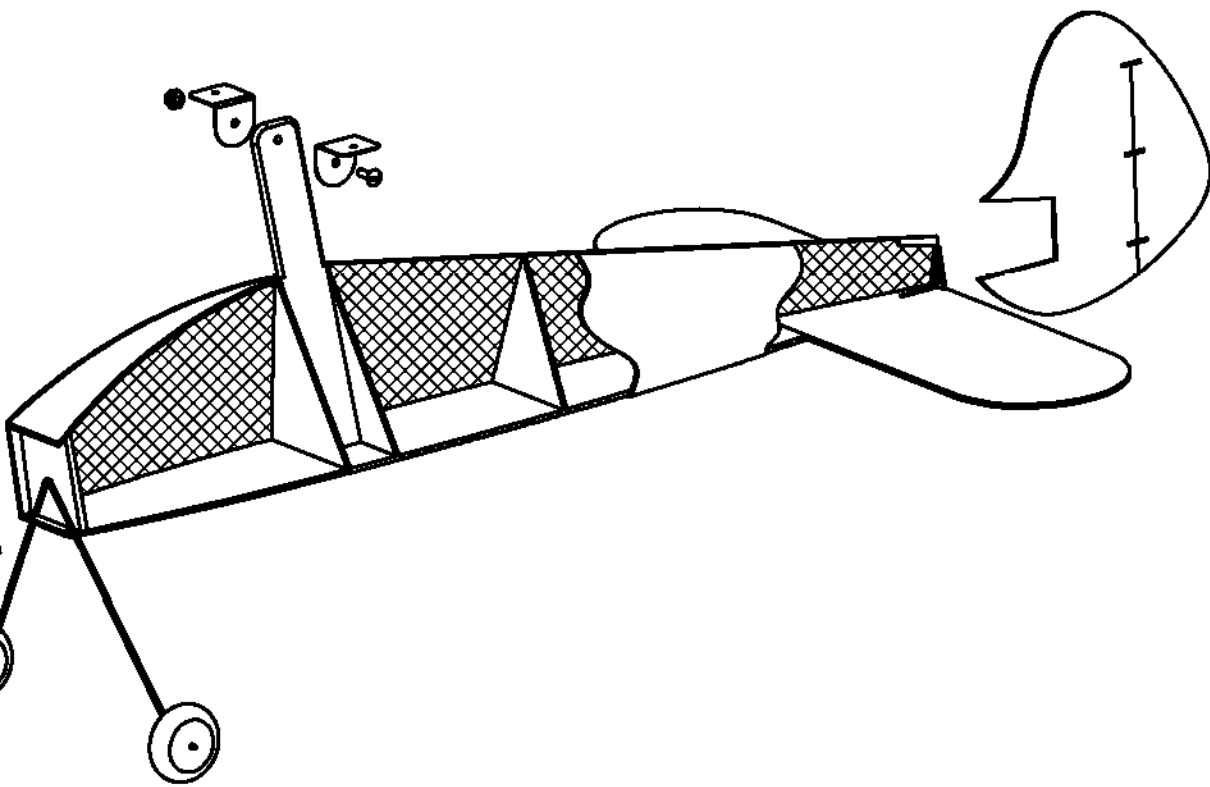
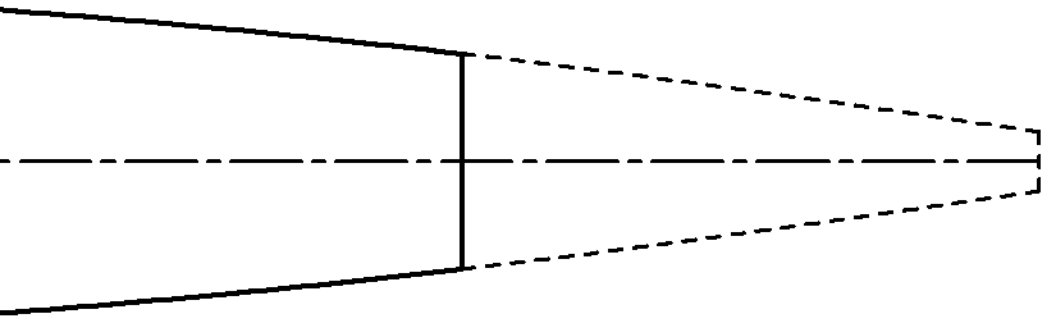

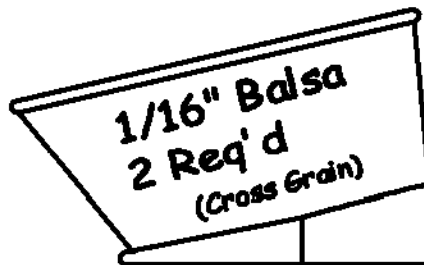
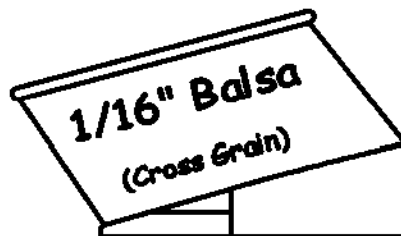
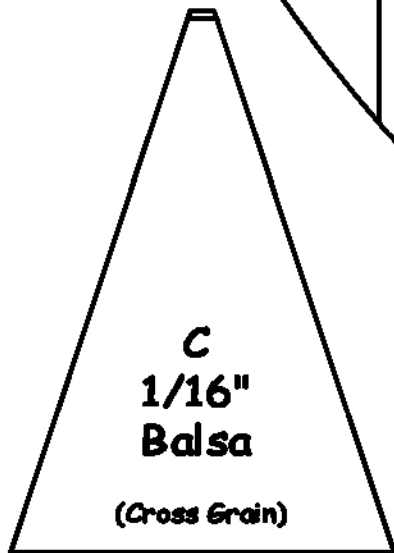

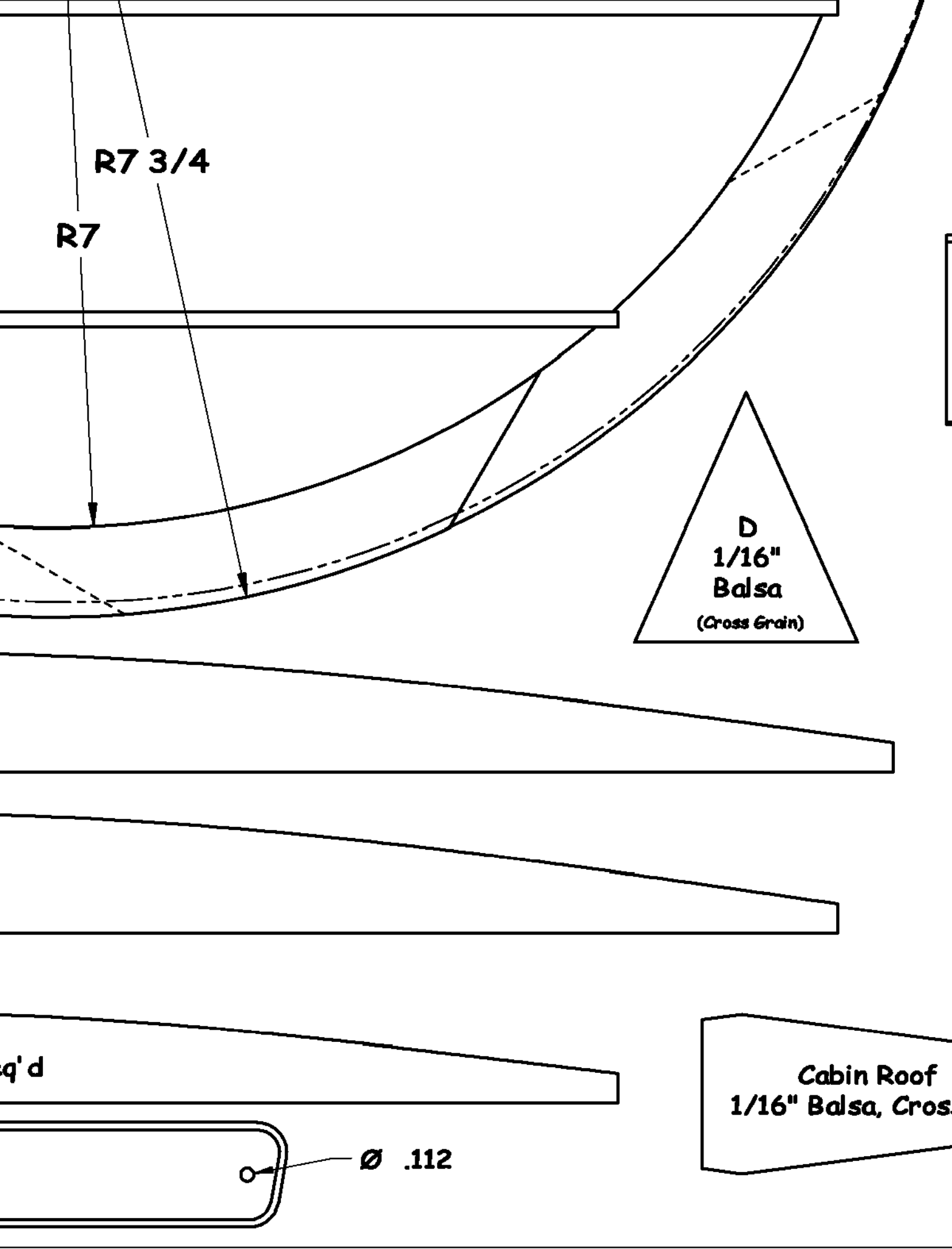

R7 3/4

R7

D
1/16"
Balsa
(Cross Grain)

q'd

Cabin Roof
1/16" Balsa, Cross

Ø .112

A
1/8" Ply

B
1/8" Ply

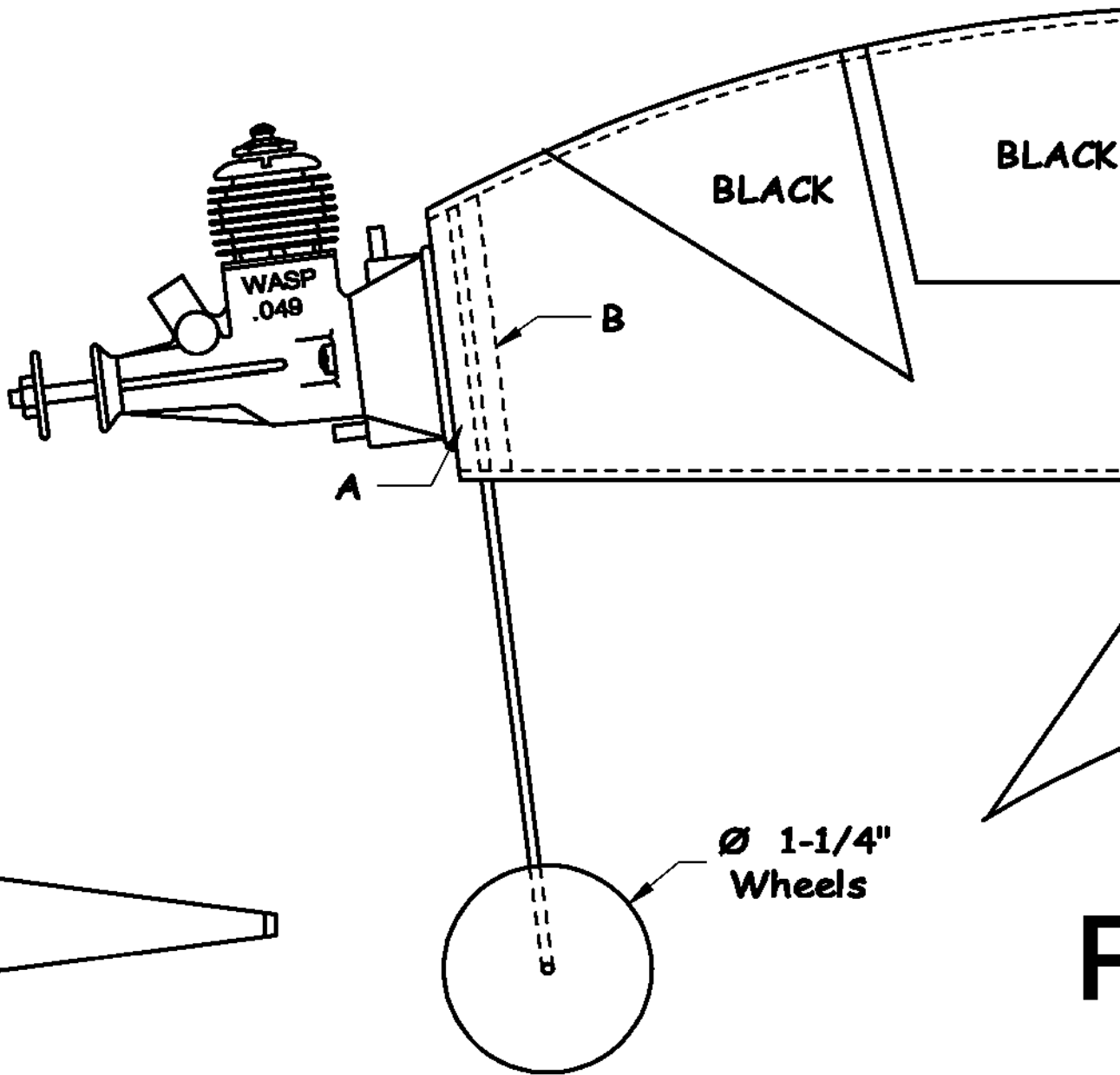

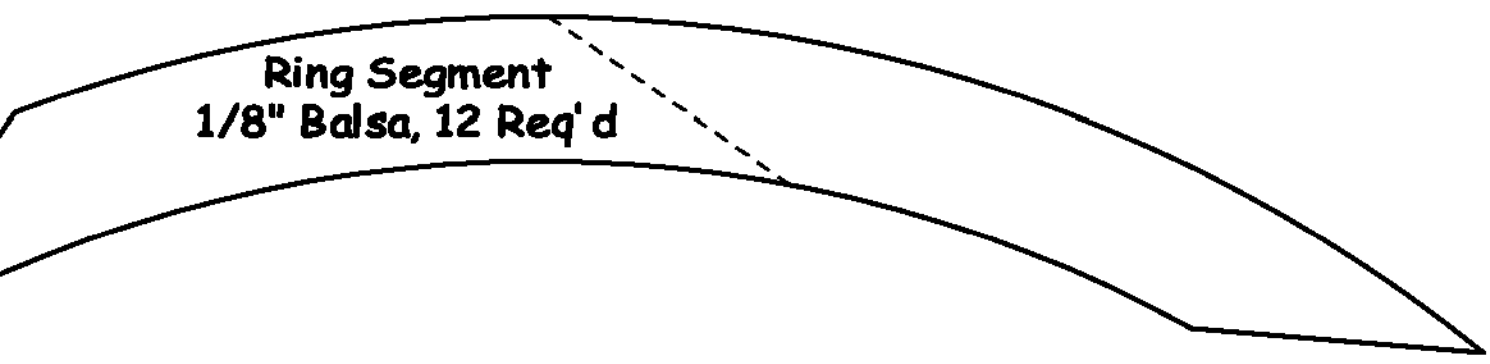
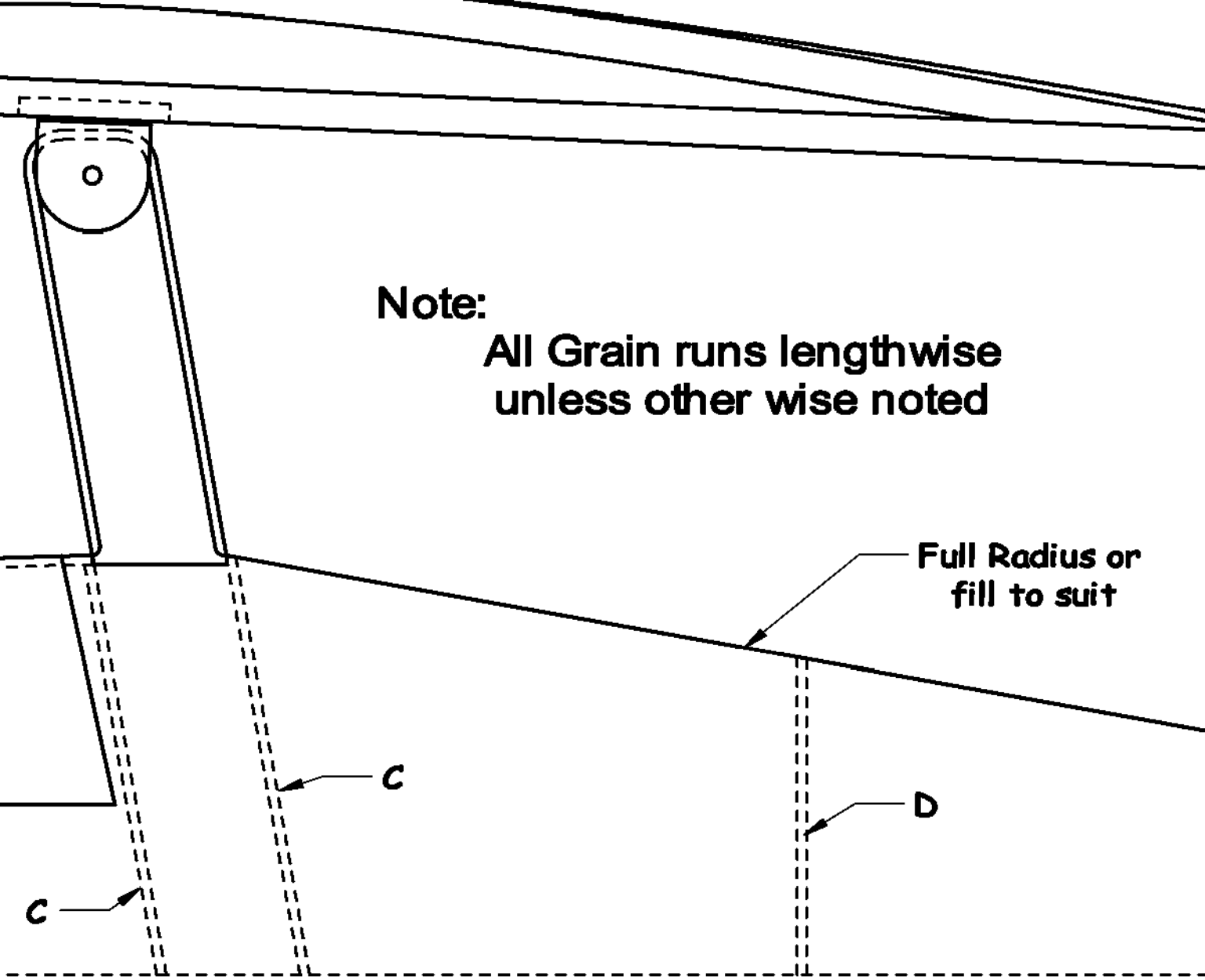

PARASOL PLANE

By: Roy L

POPULAR MECHANICS JULY, 1964

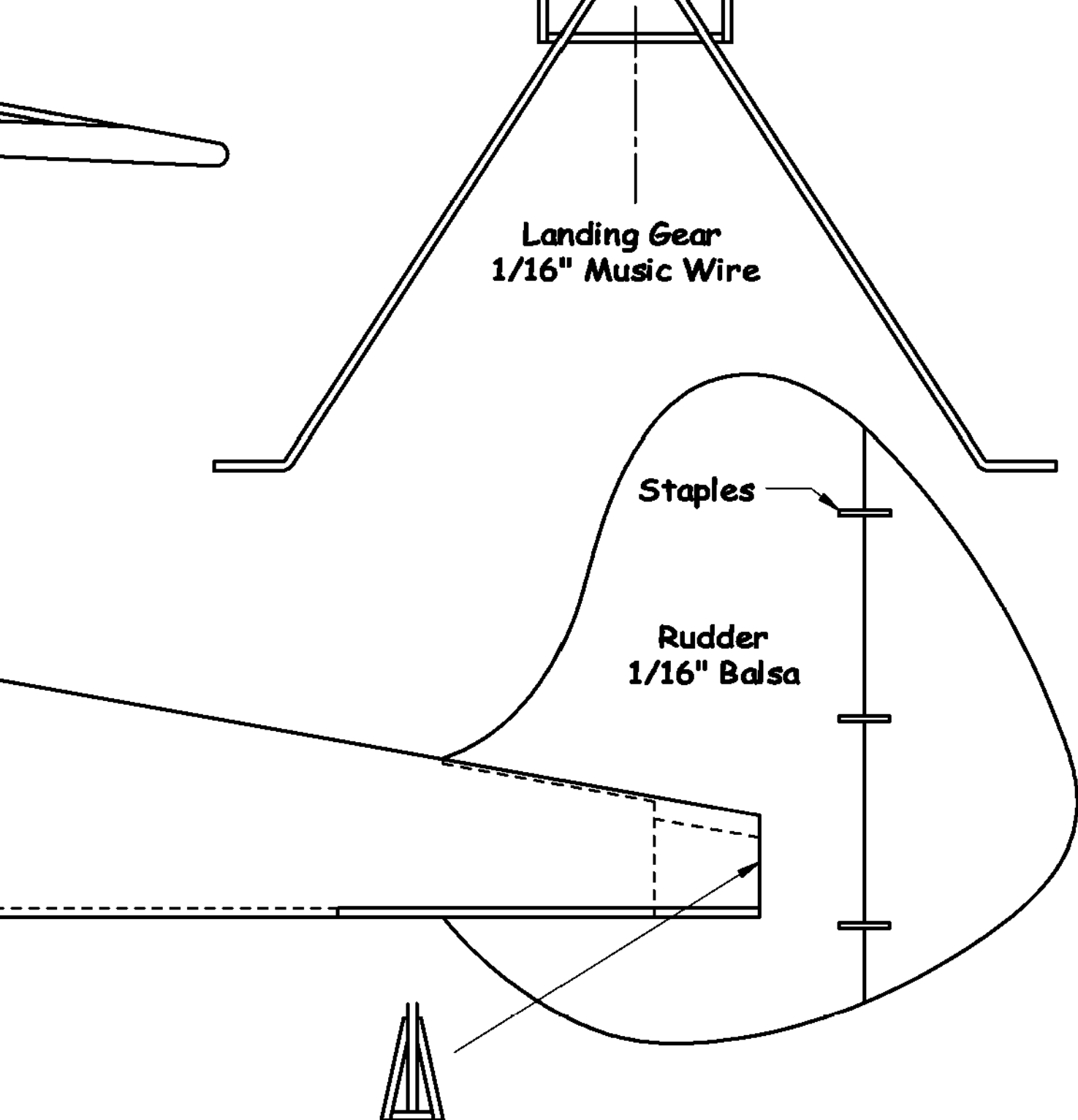

.. Clough, Jr.

Cad By: Gene Rock 2004

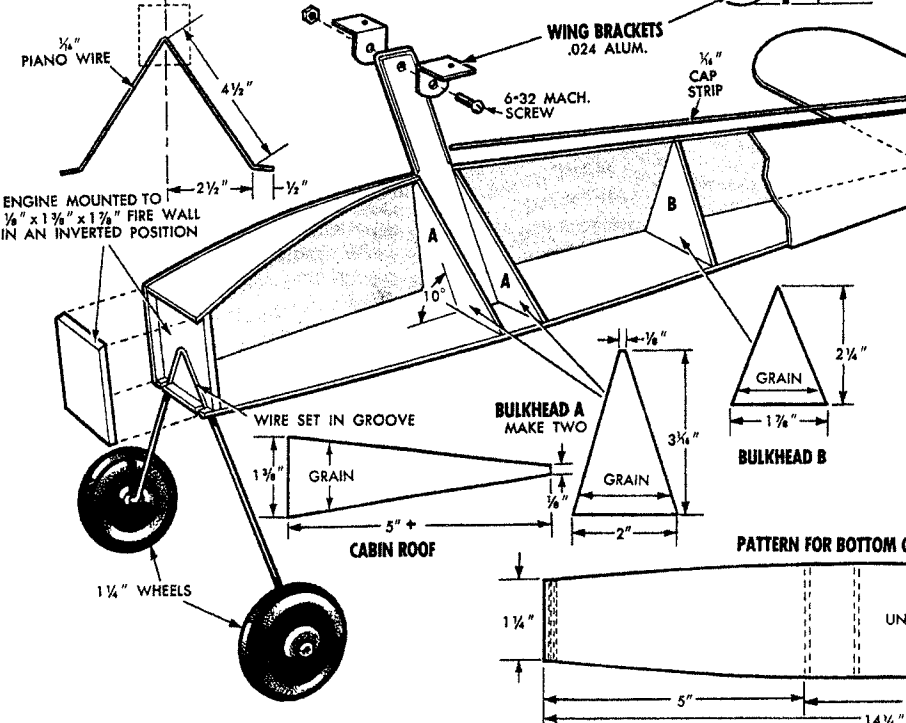
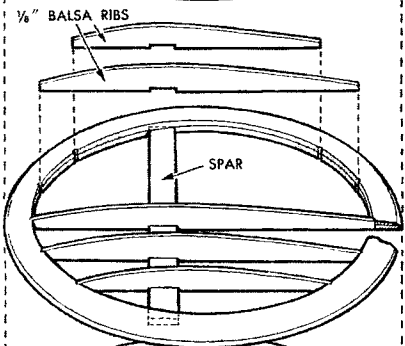
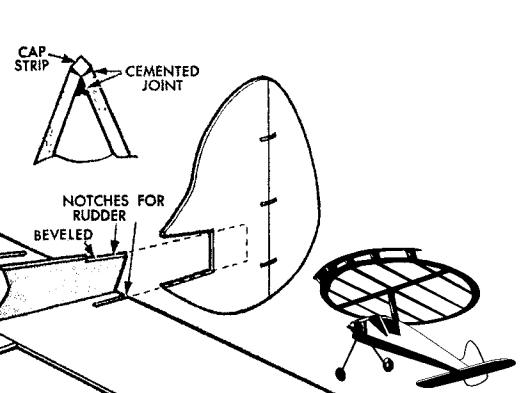
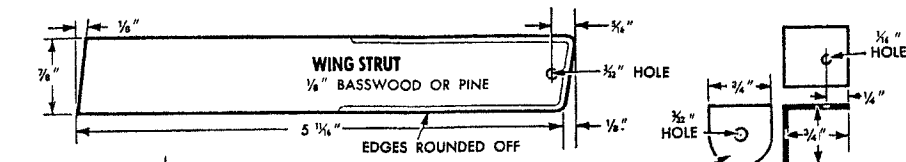
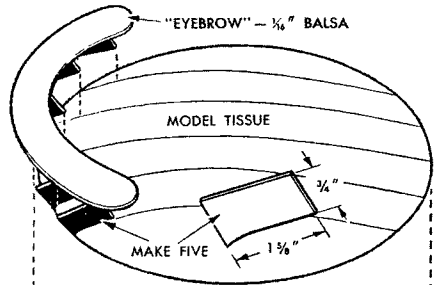
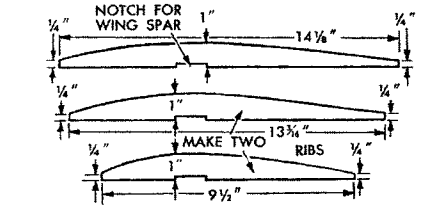
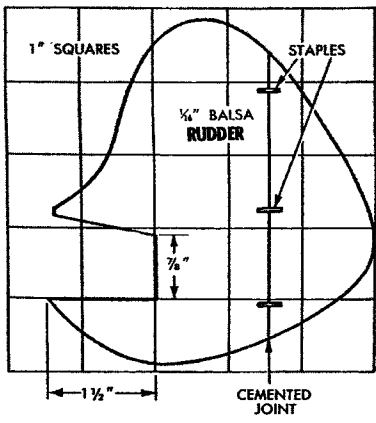
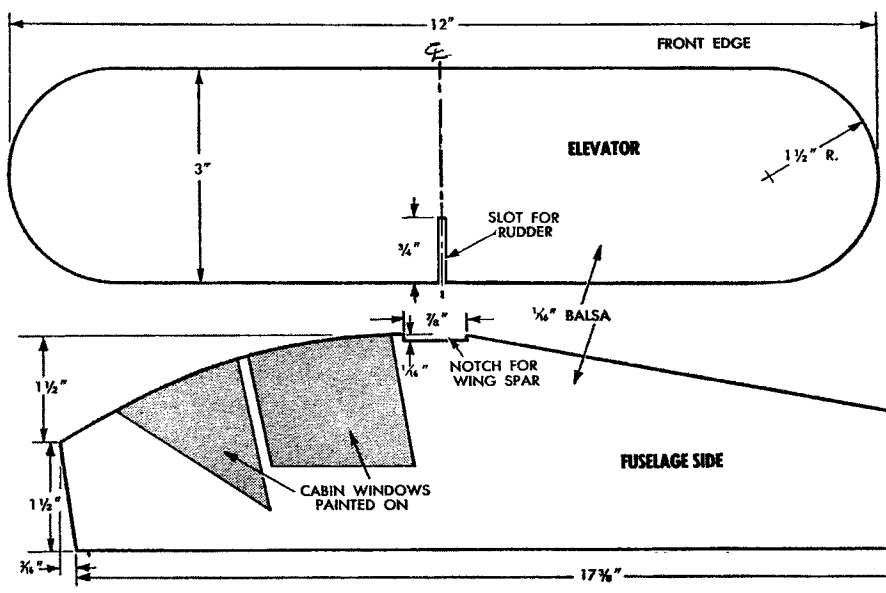

ANGLE OF CLIMB is controlled by the rudder. If model climbs too steeply, tighten turn by bending the rudder tap (bend the staples with a small pair of pliers). It's recommended that you fly it in left-hand circles to take advantage of stabilizing gyroscopic moment provided by the right-hand propeller.

